



MOTOROLA INC.
Communications
Group

MOTOROLA HF-SSB Automatic Antenna Tuner

Models T1961A and T1962A
Installation Procedure

1. INTRODUCTION (Refer to Figure 1.)

1.1 Motorola HF-SSB Automatic Antenna Tuners, Models T1961A and T1962A, are antenna matching networks rated at 125 watts peak-envelope-power (PEP). Model T1961A Antenna Tuner matches the impedance of an end-fed antenna (vertical whip or random length wire) into a nominal 50-ohm impedance source with a frequency range from 2-to-18 MHz. Model T1962A Antenna Tuner performs the same impedance match, but it can be used only with a 23' whip antenna and at a frequency range from 2-to-9 MHz.

1.2 Automatic tuning is accomplished through microprocessor control of reed relays that switch inductors and capacitors in and out of the matching network. The balance of this installation procedure describes preinstallation instructions, installation instructions and ground systems for the radio and the antenna tuner.

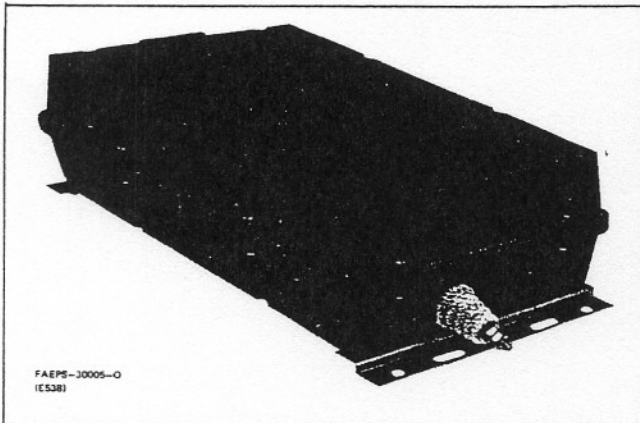

Figure 1. Automatic Antenna Tuner

2. PREINSTALLATION INSTRUCTIONS

2.1 TUNE POWER ADJUSTMENT

CAUTION

The following adjustments to the TRITON 20 or TRITON 12 and 24 channel radios must be performed before making electrical connections to the antenna tuner.

2.1.1 TRITON 20 Adjustment

Step 1. In the TRITON 20 instruction manual (68P81044E20), refer to the TRN4038A Power Amplifier circuit board overlay and schematic.

Step 2. With the radio in the TUNE MODE, adjust potentiometer R441 for 3 watts \pm 1 watt of power output into a 50-ohm resistive load.

2.1.2 TRITON 12 and 24 Channel Adjustment

Step 1. In the TRITON 12 and 24 channel radio instruction manuals (68P81030E35 and 68P81034E05), refer to the TLN1752A Power Amplifier circuit board overlay and schematic diagram.

Step 2. With the radio in the TUNE MODE, adjust potentiometer R41 for 3 watts \pm 1 watt of power output into a 50-ohm resistive load.

2.2 RADIO MODIFICATIONS

2.2.1 The TRITON 20 and TRITON 12 and 24 channel radios require circuitry modification *if they were built before July 1, 1980*. Those radios built after this date do not require the following modifications. All the components required for these modifications are in a small package of parts supplied with the antenna tuner. Since components for both radios are included, some components are not used, depending upon which radio is modified.

2.2.2 TRITON 20 Modifications

(Refer to Table 1, and Figures 2 and 3.)

The TRITON 20 modification consists of the addition of 2 components to a circuit board.

Step 1. In the TRITON 20 instruction manual, locate the TRN4032A "A" circuit board overlay and schematic diagram.

Step 2. Select the components listed in Table 1, and install the diode and resistor as illustrated in Figure 2.

Table 1. TRITON 20 Modification Parts List

Reference Symbol	Motorola Part No.	Description
CR110	48-83654H01	Diode, silicon (1 req'd.)
R198	6-124C25	Resistor, fixed, 100 ohm, 10%, 1/4 watt

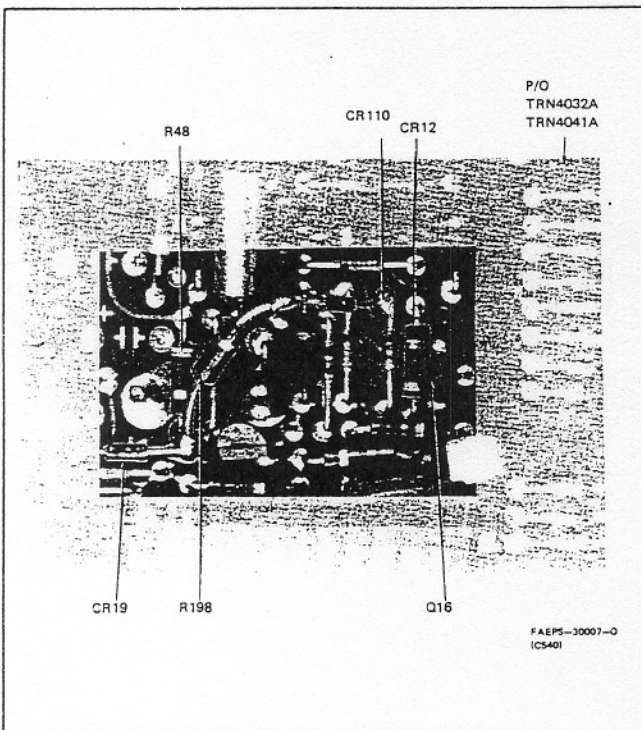

Figure 2.
TRITON 20 Circuit Board Modifications

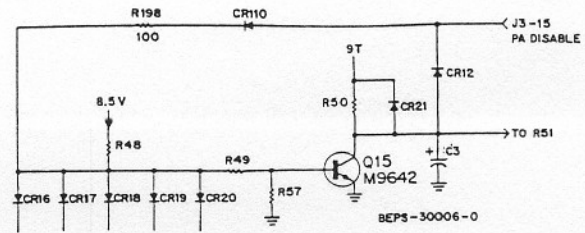

Figure 3.
TRITON 20 Schematic Diagram Modifications

2.2.3 TRITON 12 and 24 Channel Radio Modifications

(Refer to Table 2 and to Figures 4 thru 7.)

The TRITON 12 and 24 channel radio modifications consist of changes made on two separate circuit boards. The first modification is done to the main circuit board by addition of components listed in Table 2. Figures 4 and 5 illustrate where these components are installed. The second modification is done to the transmit/receive switch circuit board by the addition of components listed in Table 2. Figures 6 and 7 illustrate where these components are installed.

CAUTION

Early versions of 12 and 24 channel TRITON radios must have resistor R44 on TLN1752A Power Amplifier changed to a 3.3k ohm, 5%, 1/4 watt resistor for proper antenna tuner operation.

Step 1. In the TRITON 12 and 24 channel radio instruction manuals, locate the TUA1110A or TUA1120A Universal Radio Chassis and Main Board "M" overlay and schematic diagram.

Step 2. Select the components (CR519 thru CR523 and R518) listed in Table 2, and install the diodes and resistor as illustrated in Figure 4. Use sleeving on the component leads.

Table 2. TRITON 12 and 24 Channel Radio Modification Parts List

Reference Symbol	Motorola Part No.	Description
CR9	48-84616A01	Diode, hot carrier (1 req'd.)
CR519 thru CR523	48-83654H01	Diode, silicon (5 req'd.)
R24, R518	6-124C25	Resistor, fixed, 100 ohm, 10%, 1/4 watt (2 req'd.)
R44	6-124A61	Resistor, fixed, 3.3k ohm, 5%, 1/4 watt (1 req'd.)

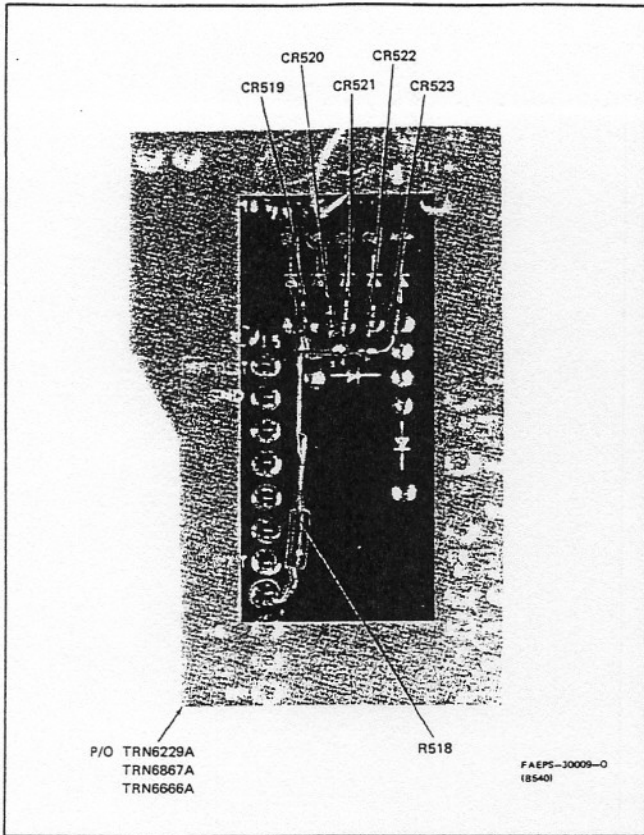

Figure 4.
TRITON 12 and 24 Channel Main Circuit Board
Modifications

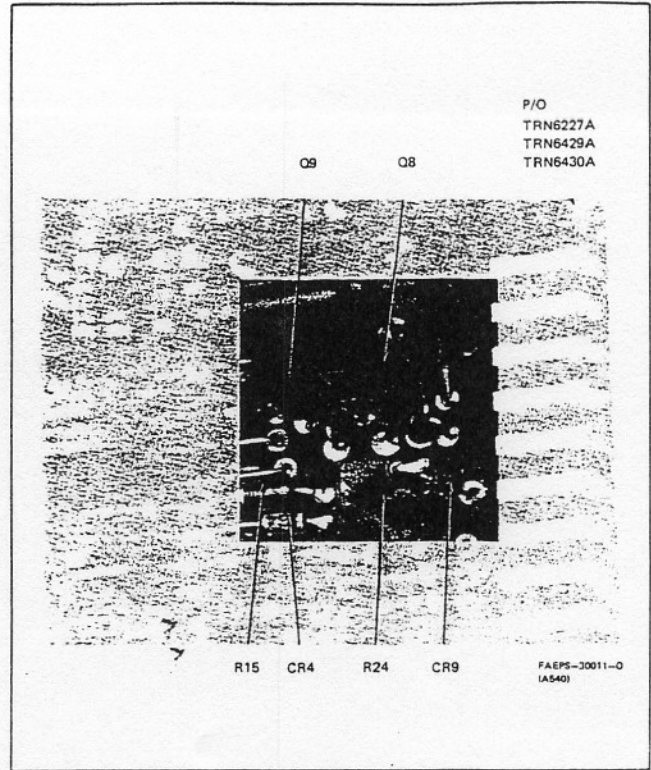

Figure 6.
TRITON 12 and 24 Channel Small Circuit Board
Modifications

P/O BANDSWITCHING
CIRCUITRY SECTION ON
MAIN BOARD "M"

CATHODE OF CR416 (RANGE 1)	CR519
CATHODE OF CR417 (RANGE 2)	CR520
CATHODE OF CR418 (RANGE 3)	CR521
CATHODE OF CR419 (RANGE 4)	CR522
CATHODE OF CR420 (RANGE 5)	CR523
CATHODE OF VR425 (PA DISABLE)	R518
	100

BEPS-30008-0

Figure 5.
TRITON 12 and 24 Channel Main Circuit Board
Schematic Diagram Modifications

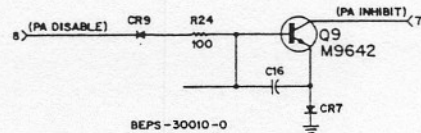

Figure 7.
TRITON 12 and 24 Channel Small Circuit Board
Schematic Diagram Modifications

Step 3. In the instruction manual, locate the TRN6227A, TRN6429A, or TRN6430A Transmit/Receive Switch circuit board overlay and schematic diagram.

Step 4. Remove resistor R24 (220 ohm) from the circuit board and lay it aside. It will not be used.

Step 5. Select the components (CR9 and R24) listed in Table 2, and install the diode and resistor as illustrated in Figure 6.

3. INSTALLATION INSTRUCTIONS

3.1 GENERAL

The procedure for a good installation is essentially the same for either the Model T1961A or Model T1962A Antenna Tuner. If the Model T1961A Antenna Tuner is employed, antennas of the end-fed variety of a 23-foot whip or up to a 60-foot long wire may be used with a frequency range from 2 to 18 MHz. If the Model T1962A Antenna Tuner is employed, its use is limited to a 23-foot whip antenna with a frequency range from 2 to 9 MHz. The antenna should be installed as close as possible or within a maximum of 3 feet of the tuner. The ground system should be as close as possible or within a maximum of 5 feet of the tuner.

3.2 LOCATION (Refer to Figure 8.)

Selection of a location for the antenna tuner should be such that it is as close to the antenna as possible. Long "lead-in" wires greatly increase the possibility of creating radio frequency interference (RFI) with other electronic equipment on the vessel. There are two factory installed angle brackets attached to the bottom of the antenna tuner for mounting purposes. Several holes and slots are provided on each bracket. It is not necessary to remove the brackets to mount the tuner.

NOTE

The dealer or installer must supply the necessary stainless steel mounting hardware.

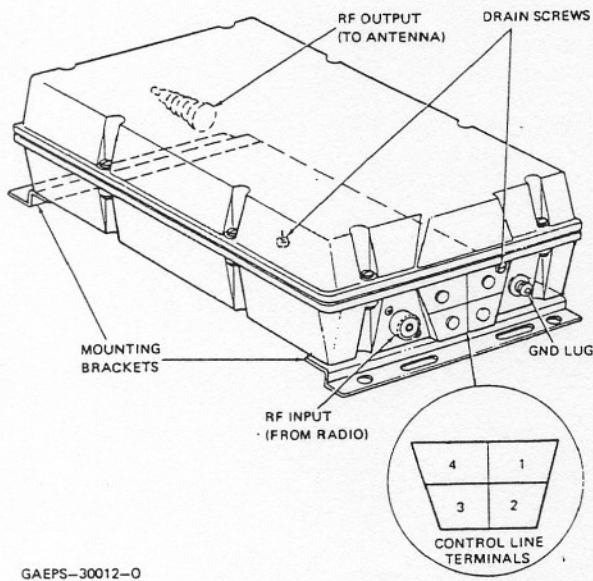

Figure 8. Antenna Tuner Housing

3.3 DRAIN SCREW REMOVAL (Refer to Figure 9.)

The antenna tuner has provisions for selection of one of two drain screws for removal of condensation. One screw is positioned on the bottom of the housing, and the other is on the end of the housing. Proper orientation of the drain hole is essential for normal tuner operation. Remove and discard one screw from the surface that will be at the lowest position when the tuner is mounted.

CAUTION

Regardless of antenna tuner mounting position, the selected drain hole must face downward.

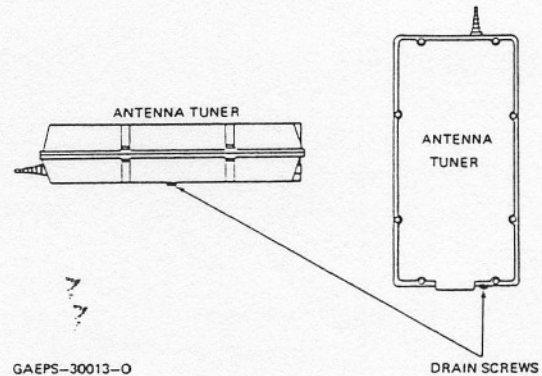

Figure 9. Mounting Positions

3.4 GROUNDING

A good ground system is required for efficient antenna tuner operation. Use the ground lug on the antenna tuner for ground strap attachment. Ground returns for the electrical circuits may be provided through the deck or hull of the vessel if these are metallic; otherwise, a copper strap four inches wide should be installed from bow to stern. For more detailed information regarding grounding, refer to the GROUND SYSTEMS section of this manual.

WARNING

Do not install the antenna tuner without an adequate ground system.

3.5 CONTROL CABLE ASSEMBLY AND INSTALLATION

The control cable must be field assembled. Table 3 lists the items required for assembly of the cable. Of those parts listed, the connector kit and solder lugs are supplied with the antenna tuner, but the 3-conductor cable must be supplied by the dealer or the installer. The following steps outline the control cable assembly and installation procedure.

Table 3. Control Cable Parts List

Motorola Part No.	Description
TRN4423A	Connector Kit (1 req'd)
29-3388-008	Solder lugs (3 req'd)
	3-Conductor Cable, color-coded, stranded, 18-gauge for lengths up to 100'

* For a detailed parts breakdown of the TRN4423A Connector Kit, see PEPS-30105 at the rear of this manual.

Step 1. Assemble the control cable as illustrated in Figure 10 and as directed in Figure 11.

Step 2. Insert the completed 15-pin plug into the antenna tuner connector of the TRITON radio.

Step 3. Route the other end (solder lugs) of the control cable through the vessel to the antenna tuner.

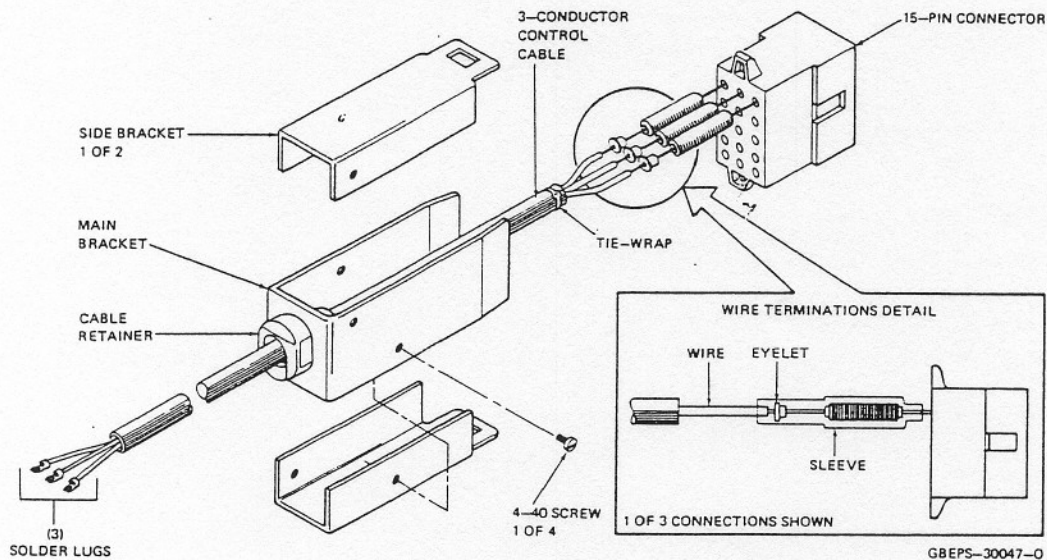

Figure 10. Control Cable Assembly

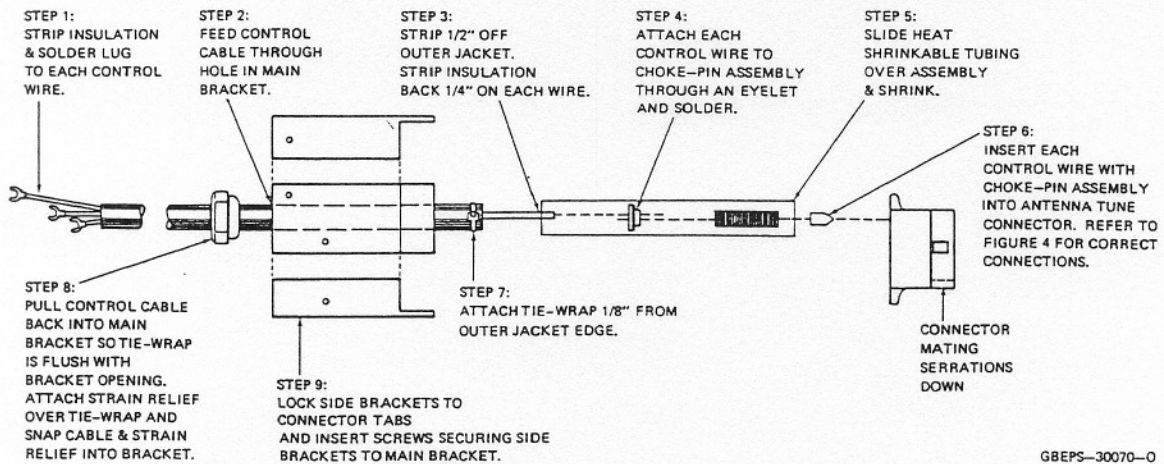

Figure 11. Control Cable Assembly Procedure

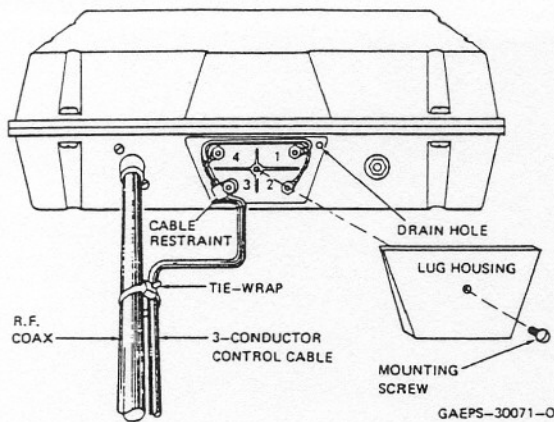

Figure 12.
Electrical and Mechanical Connections

Step 4. Route and connect the solder lugs of the control cable as shown in Figure 12. Tie-wrap the control cable to the coaxial cable, and attach the lug housing with mounting screw.

3.6 COAXIAL CABLE (Refer to Figure 13.)

Use type RG-58/U or RG-8/U, 50-ohm, coaxial cable with the appropriate UHF connectors (PL-259) on both ends to interface the RF OUTPUT from the radio to the RF INPUT to the antenna tuner.

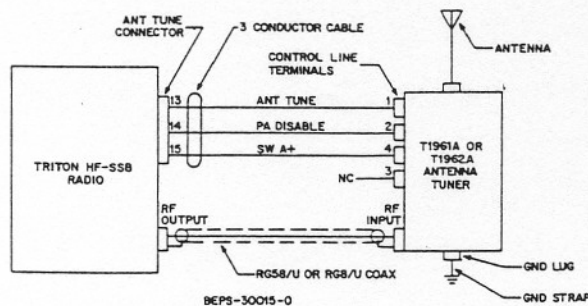

Figure 13. Electrical Block Diagram

4. GROUND SYSTEMS

(Refer to Figures 14 and 15.)

4.1 A common ground for the entire radio system (radio, dc power supply, antenna tuner, etc.) is required for proper system performance. This type of grounding is accomplished through the use of three inch wide grounding straps terminating at the GROUND LUG on the antenna tuner, which in turn is connected to the antenna ground plane. When at all possible, avoid multiple path ground connections. They result in ground loops which may have high circulating currents. On certain operating frequencies, ground loops cause radio and/or antenna tuner instability.

4.2 The ground strap to the antenna tuner must be within a *maximum* of 5 feet of the tuner. If the ground strap is long in terms of the operating frequency wavelength, it can actually present a high impedance to the ground lug on the antenna tuner. As a result, the antenna tuner is electrically "floating" above the reference ground of the system.

4.3 An adequate system ground is usually easily obtained on a metal hulled ship with a metal deck. All communications equipment can be grounded to the metal structure of the ship at convenient places.

4.4 Wood and fiberglass vessels present more difficult grounding problems. Large ground straps are required to electrically bond equipment together, and an artificial ground plane must be created. Either of two methods is used to achieve the required ground plane: ground plates or screening. Ground plates or screening is installed inside the hull of the craft so that good electrical contact with the water is made through the capacitive effect of the hull (dielectric). At least 100 square feet of the area below the water line is recommended. Figure 14 shows an example of a ground system where a ground plate is placed on the inside of the hull of the vessel.

4.5 An artificial ground plane can be further improved with the addition of copper screening connected through a ground strap to the base of the antenna tuner and placed in the immediate vicinity of the antenna tuner. The antenna tuner should also be grounded to copper pipes, the metal water tank, and the engine to extend the ground system. The addition of 1/4 wavelength radials extending from the ground lug of the antenna tuner creates a further improvement in system performance. Figure 15 shows a radial ground system.

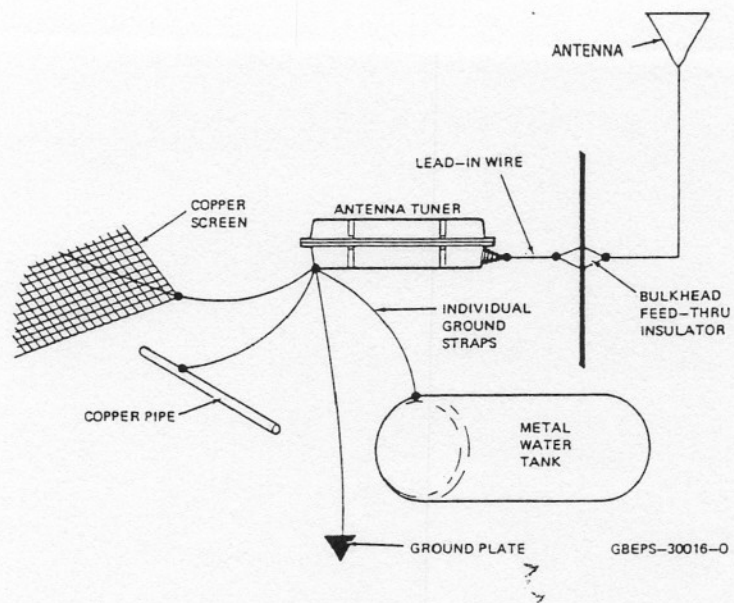

Figure 14.
Ground System on Fiberglass Vessel

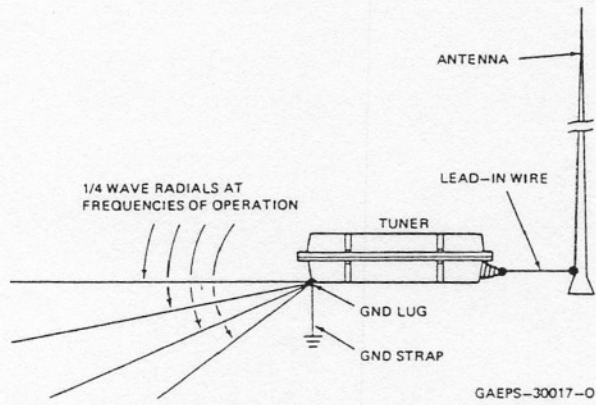

Figure 15. Radial Ground System

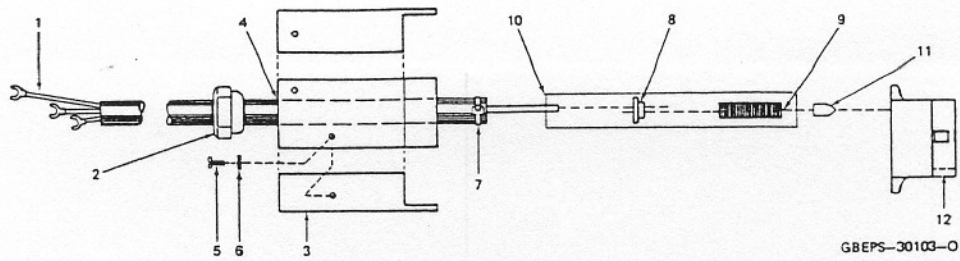

Figure 16. Control Cable Parts Detail

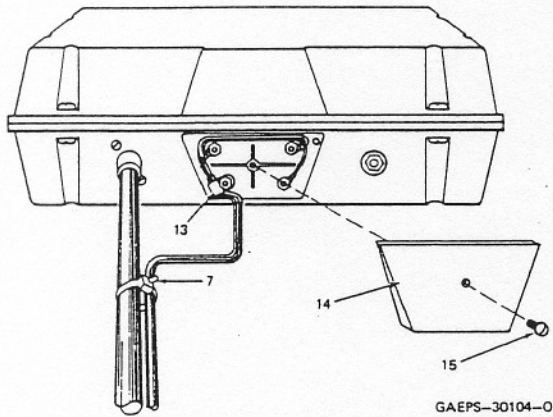

Figure 17. Housing Parts Detail

parts list

TRN4423A Connector Kit

PL-6953-O

CODE	MOTOROLA PART NO.	DESCRIPTION
1	29-83883C08	LUG, solder; 3 used
2	42-82018H02	STRAIN RELIEF
3	7-82232L01	BRACKET, side; 2 used
4	7-82233L01	BRACKET, main
5	3-115613	SCREW, machine; 4-40 x 1/4"; 4 used
6	4-135851	LOCKWASHER, #6 split; 4 used
7	42-10217A02	TIE-WRAP; 2 used
8	5-82050H04	EYELET; 3 used
9	24-83397L01	CHOKE, RF, 30 uH; 3 used
10	37-132049	TUBING, clear 1/4"; 3 used
11	29-84150L02	TERMINAL, plug; 3 used
12	14-82834H02	INSULATOR, plug; 15 pin
13	42-10283A20	CLIP, cable
14	14-84495M01	INSULATOR
15	3-139102	SCREW, tapping; 8-18 x 1/2"



MOTOROLA INC.

Communications
Group

MOTOROLA HF-SSB AUTOMATIC ANTENNA TUNER

MODELS T1959A, T1961A, T1962A

1. DESCRIPTION

1.1 Motorola HF-SSB automatic antenna tuners are antenna matching networks rated at 125 watts peak-envelope-power. Selection of the network components for antenna matching is performed by a microprocessor-based circuit that monitors antenna conditions each time a channel is changed. The entire tuning process usually takes less than one second. Microprocessor control eliminates the need for programming, preset adjustments, manual tuning, or manual adjustments during installation or operation.

1.2 The automatic antenna tuner can accommodate any number of channels automatically. New channels can be added at any time without adjusting the tuner.

1.3 The automatic antenna tuner includes stainless steel hardware and a weather resistant housing that insure corrosion resistance and durability. Installation is simplified; the automatic tuning capability eliminates the need to open the tuner housing during installation.

1.4 Models T1959A and T1961A match the impedance of an end-fed antenna (23-35 foot vertical whip or 23-60 foot random length wire) into a nominal 50-ohm

impedance source with a frequency range from 2-18 MHz. Model T1961A includes the TRN4423A connector kit for field assembly of the necessary control cables. Model T1959A uses factory assembled accessory cables, TKN8123A, TKN8120A and TKN8121A. Otherwise, the T1959A and T1961A are identical. T1959A and T1961A Antenna Tuners are compatible with the 102-inch mobile whip antenna (TAA1000A) from 2-18 MHz if a TKN8119A antenna matching harness is used.

Model T1962A Antenna Tuner is capable of matching a 23-foot whip antenna from 2-9 MHz. This model also includes the field assembled TRN4423A connector kit.

NOTE

Older versions of Motorola single side-band radios must be modified before they can be used with these tuners. Please refer to the installation manual for the specific tuner for more details. Installation manual 68P81111E16 applies for tuner Model T1959A. Installation manual 68P81110E64 applies for Models T1961A and T1962A.

2. MODEL COMPLEMENTS

T1959A 2-18 MHz Base Tuner consists of:

- TLA1102A
 - THN6410A
 - TLA6102A

T1961A 2-18 MHz Tuner consists of:

- TRN4423A Connector
- TLA1102A Tuner
 - THN6410A Housing
 - TLA6102A RF Board

T1962A 2-9 MHz Tuner consists of:

- TRN4423A Connector
- TLA1112A Tuner
 - THN6410A Housing
 - TLA6112A RF Board

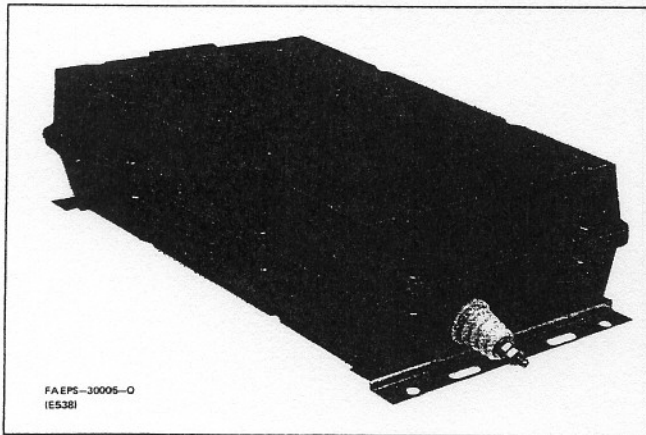

Figure 1. Automatic Antenna Tuner

3. PRE-OPERATIONAL CHECK

- 3.1 The antenna tuner is thoroughly checked and inspected at the factory. However, if the tuner is to be installed in a remote location or stocked on a shelf for several months, a pre-operational check on a service bench is recommended.
- 3.2 The recommended set-up for the pre-operational check consists of all the components that comprise

the radio system (with the antenna being replaced by an antenna simulator circuit). The recommended set-up is shown in Figure 2.

NOTE

A TKN8119A Mobile Antenna Matching Harness must be used when checking a mobile whip antenna. Figure 3 shows a recommended set-up.

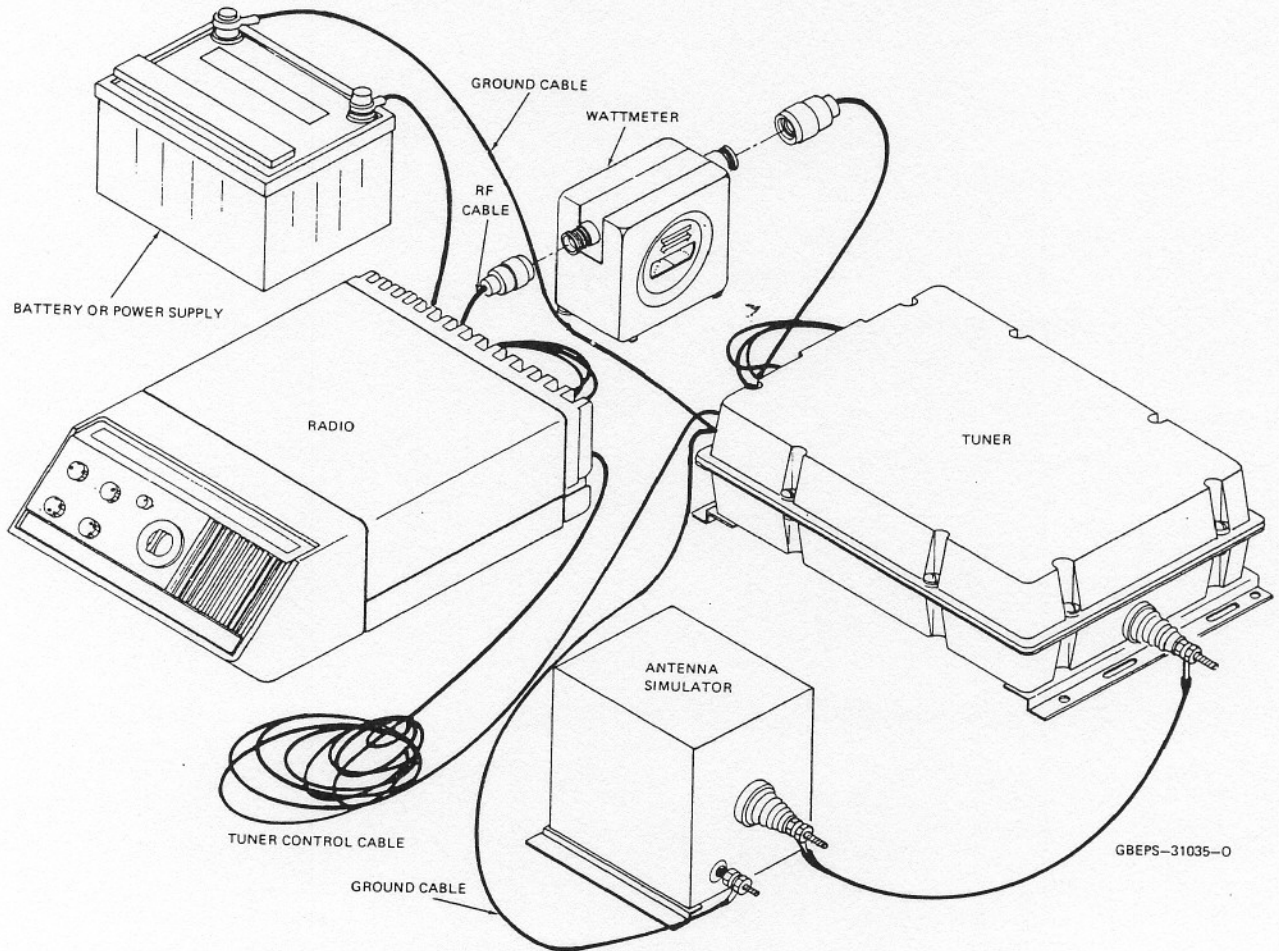

Figure 2. Typical Pre-Operational Check Configuration

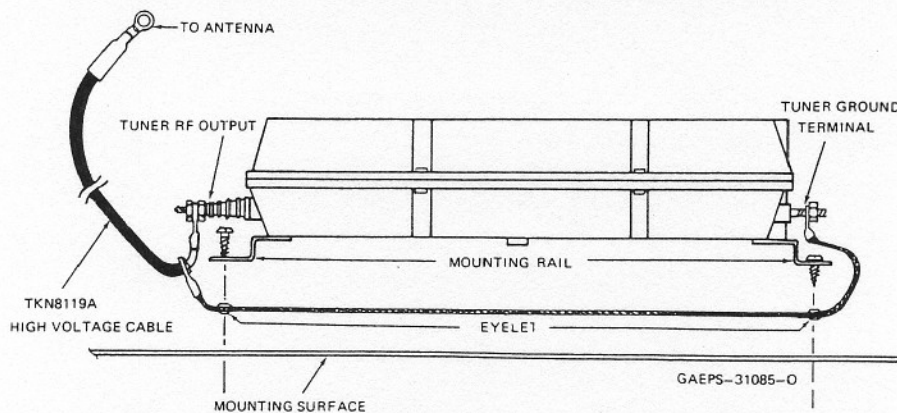

Figure 3. TKN8119A Mobile Antenna Matching Harness

3.3 Circuits for construction of the antenna simulator are shown in Figures 4 through 6.

NOTE

Figures 4 and 5 apply only for 23 to 60 foot antennas, whip or long wire.

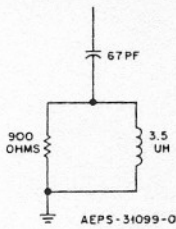

Figure 4. Antenna Simulator Circuit for Models T1959A, T1961A, T1962A (2-10.8 MHz)

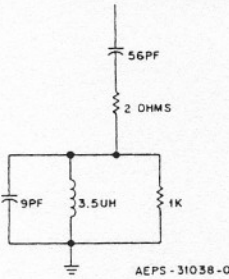

Figure 5. Antenna Simulator Circuit for Models T1959A and T1961A (10.8-18 MHz)

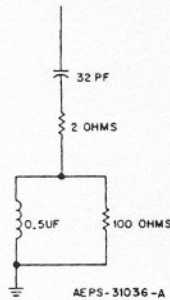

Figure 6. Mobile Whip Antenna Simulator Circuit

3.4 Select and construct the antenna simulator circuit that corresponds to the antenna tuner model being checked and the operating range of the radio.

CAUTION

These antenna simulator circuits are only recommended for system tests in the tune-up mode. Tests in other modes should only be made if the simulator circuits are constructed with parts that are rated to handle maximum transmitter power.

3.5 To insure proper operation of the tuner, the radio must be adjusted for a power level (in the tune

mode) of 3 ± 1 watts into a 50-ohm load. Refer to the radio instruction manual for the procedure for adjusting the radio power level in the tune mode.

3.6 Check the tuner operation by following the procedure given below.

Step 1. Set up the components of the radio installation as shown in Figure 2.

Step 2. Select Channel 1 and turn the radio on. During the initial 1 to 2 seconds, the wattmeter should indicate a power level of approximately 3 watts. The radio should then return to the receive mode.

CAUTION

Step 3 should only be performed with an antenna simulator rated for full transmit power or with a properly installed antenna.

Step 3. Whistle into the microphone. Check the wattmeter for forward and reverse power levels. The forward power level should be more than three times the reverse power level.

Step 4. Repeat Steps 2 and 3 for each of the other radio channels. Insure that the proper antenna simulator is used for each channel frequency.

4. MAINTENANCE

4.1 RECOMMENDED TEST EQUIPMENT

The test equipment listed in Table 1 is recommended for maintaining and troubleshooting the automatic antenna tuner.

Table 1. Recommended Test Equipment

Equipment Type	Recommended Model	Purpose
DC Multimeter	Motorola S-1063	Measure dc voltages
Oscilloscope	R-1004	Checking waveforms
In-line Wattmeter	S-1350	Measuring forward and reverse power
50-ohm RF Load	T-1013	Dummy load used for setting tune power level
Antenna Simulator	See Figures 4-6	Substitute for antenna
Motorola SSB Radio		RF source

4.2 PREVENTIVE MAINTENANCE

4.2.1 Check all external surfaces of the equipment to see that they are clean. Inspect all connecting cables and wires for damage or loose connections. It is especially important that the ground and antenna wires make good connections at the tuner. Carefully check the antenna and verify that it is properly insulated from any metal objects.

4.2.2 If the equipment surfaces are dirty, wash the external surfaces with mild soap and water using a clean cloth. Be careful not to allow the electronic components or connectors to get wet.

4.2.3 Preventive maintenance should be scheduled regularly, i.e. monthly, quarterly, annually. The interval of maintenance depends on equipment usage and environment.

4.3 TROUBLESHOOTING

Check for proper operation of the tuner by performing the procedure listed under the Pre-Operational Check paragraph of this manual. If the tuner is not operating properly, use the notes on the schematic diagram and the attached troubleshooting chart to localize the defective component.

5. THEORY OF OPERATION

5.1 CIRCUIT FUNCTION

A fixed length antenna presents greatly varying impedances when operating over a wide frequency range. The tuner must enable the antenna to resonate by compensating for the capacitive or inductive reactance present. It must also match the resistive component of the antenna to present a 50-ohm load to the radio output. This antenna tuner is designed to perform both of these functions automatically in less than 2.5 seconds without making any preliminary adjustments or settings.

5.2 CIRCUIT CONFIGURATIONS

Two different circuit configurations are used to tune the antenna. To match antennas with capacitive reactance, a pi configuration is used. The pi configuration consists of parallel capacitance, followed by series inductance, followed by parallel capacitance. To match antennas with inductive reactance, an L configuration is used. The L configuration consists of series inductance followed by parallel capacitance.

5.3 CIRCUIT DESCRIPTIONS

5.3.1 Tuning Elements

5.3.1.1 The tuning elements of the antenna tuner consist of inductive and capacitive components that are switched into the rf circuit by a series of reed relays. The tuning elements are selected by the tuner microcomputer, which enables the transistor driver circuits that activate the relays. The tuning element network consists of parallel capacitance, followed by series inductance, followed by parallel capacitance. In addition, there is an output inductance of 26.25 microhenries that can be selected by the microcomputer and a

fixed output capacitance of 50 picofarads.

5.3.1.2 There are five steps of switchable input capacitance arranged in a binary order, that is, the value of a switchable capacitance is half the value of the next largest switchable capacitance. The values of switchable input capacitance are 2000, 1000, 500, 250, and 120 picofarads. The values of switchable output capacitance for Models T1961A and T1959A are 400, 200, 100, 50, and 27 picofarads. The values of switchable output capacitance for Model T1962A are 50 and 100 picofarads.

5.3.1.3 There are ten steps of switchable inductance arranged in binary order. The values of switchable inductance are: .08, .15, .29, .55, 1.05, 1.99, 3.8, 7.24, 13.78, and 26.25 microhenries.

5.3.2 Phase Detector

The phase detector circuit consists primarily of T1, U1, U2, U3, and U6D. This circuit compares the phase of the rf voltage to the phase of the rf current and generates either a logic high or logic low at U6-14. When the antenna and the tuner represent an inductive load to the rf output of the radio, the rf current lags the rf voltage, resulting in a logic high (5 V) at U6-14. When the antenna and tuner represent a capacitive load to the rf output of the radio, the rf current leads the rf voltage, resulting in a logic low (0 V) at U6-14.

5.3.3 VSWR Detector

The VSWR detector consists primarily of T2 and U6C. A voltage proportional to the forward power of the transmitter output is developed at U6-10. A voltage proportional to the reverse power of the transmitter output is developed at U6-11. If both U5B and U5C are not activated by the microcomputer, U6-13 drops from 5 volts to 0 volts when a VSWR of 4:1 is achieved. If U5B is activated, the 5 to 0 volt transition takes place when a VSWR of 2:1 is achieved. If U5C is activated, the 5 to 0 volt transition takes place when a VSWR of 1.5:1 is achieved.

5.3.4 Channel Change Circuit

The channel change circuit consists primarily of transistors Q28-Q33 and inverter U7C. When a radio channel change takes place, the channel change circuit applies a negative going, 0.5 second pulse to the POWER ACK and TUNED INPUT ports of the microcomputer. This pulse prohibits the microcomputer from beginning a tuning sequence until radio channel selection is complete. One-half second after the channel change is complete, there is a transition from 5 volts to 0 volts at U7-6. The transition enables the microcomputer to begin its tuning sequence. The channel change circuit responds only to channel selections made with

the channel selection knob. If channel change is initiated by the A/B button, the tune line circuit is used to initiate the tuning sequence. Refer to the paragraph that describes the tune line circuit.

5.3.5 Tune Power Detector

The tune power detector consists of U5A, U6A, and U6B. A voltage proportional to the forward power from the transmitter output is applied to U6-5. When the forward power level is between 1 and 6 watts, U5A is activated and a logic low is applied to the POWER ACK port of the microcomputer to verify that the proper power level for tuning is present.

5.3.6 Tune Line Circuit

5.3.6.1 The tune line circuit consists of U5F, U5G, U7E, U7F, and a portion of U9. During a tuning sequence, U8-33 applies a low to U7-14. The high at U7-15 activates U5G which applies a low to the antenna tune (ANT TUNE) line. A low on the ANT TUNE line enables the radio to key the transmitter on the selected channel at a low power level (approximately 3 watts).

5.3.6.2 When the radio is in the receive mode, 3.3 V is applied to the ANT TUNE line by the radio if a B channel is being received. If an A channel is being received, 12 V is applied to the ANT TUNE line. U5F is activated by the 12 volts applied during A channel reception; U5F is deactivated when 3.3 volts is applied during B channel reception. The logic high at U8-33 produces a low at U7-12 that enables the transmission gate in U9 to apply the output voltage of U5F to U8-31. The output of U5F is 0 V when an A channel is selected, 5 V when a B channel is selected.

5.3.6.3 When the tuner is not in a tuning sequence, a transition in the voltage level at U8-31 is an indication of a channel change from an A to a B channel or vice versa. This initiates a tuning sequence for the newly selected channel.

5.3.7 Voltage Control and Regulation

The voltage control and regulation circuit consists of Q23, Q24, and U4. Final voltage regulation is provided by U4.

5.3.8 Microcomputer

Microcomputer U8 controls the operation of the automatic antenna tuner. All of the programs that control tuner operation are stored in the microcomputer on-board memory.

5.4 SEQUENCE OF TUNER OPERATION

5.4.1 Power Applied

When dc power is applied to the SWITCHED A+ line (GRN), the microcomputer is reset.

5.4.2 Initialization and 4:1 VSWR Detection

The microcomputer applies a low to U8-33 to produce an 0.4 volt signal at the ANT TUNE line. The radio is enabled in the tune mode and generates an on-channel signal at approximately 3 watts. If the VSWR is greater than 4:1, U6C applies a high to U8-39 and the microcomputer begins the 4:1 VSWR tuning sequence. If the VSWR is less than or equal to 4:1, U6C applies a low to U8-39 and the tuner retains the tuning elements in the current configuration until a channel change occurs.

5.4.3 4:1 VSWR Tuning Sequence

The microcomputer begins a sequence of switching tuning elements in and out of the rf line. During the tuning sequence, the microcomputer monitors the voltage level at U8-1 and U8-39. When a 4:1 match is achieved, a low is applied to U8-39. A list of tuning elements used to achieve the 4:1 VSWR is stored in the microcomputer memory, and the microcomputer begins the 2:1 VSWR sequence. If a 4:1 VSWR cannot be achieved, the tuner reverts to the tuning configuration previously stored in the microcomputer memory and begins the termination of tuning sequence.

5.4.4 2:1 VSWR Tuning Sequence

U8-31 goes high to turn U5B on. If the VSWR is greater than 2:1, U6C applies a high to U8-39 and the microcomputer begins a sequence of switching tuning elements in and out of the rf line. (If the VSWR is less than 2:1, the 1.5:1 VSWR tuning sequence is initiated.) During the tuning sequence, the microcomputer monitors the voltage level at U8-1 and U8-39. When a 2:1 match is achieved, U6 applies a low to U8-39. A list of tuning elements used to achieve the 2:1 VSWR is stored in the microcomputer memory, and the microcomputer begins the 1.5:1 VSWR sequence. If a 2:1 VSWR cannot be achieved, the tuner reverts to the tuning configuration previously stored in the microcomputer memory and begins the termination of tuning sequence.

5.4.5 1.5:1 VSWR Tuning Sequence

U8-31 goes low to turn U5B off, and U8-32 goes high to turn U5C on. If the VSWR is greater than 1.5:1, U6C applies a high to U8-39 and the microcomputer begins a sequence of switching tuning elements in and out of the rf line. During the tuning sequence, the microcomputer monitors the voltage level at U8-1 and U8-39. When a 1.5:1 match is achieved, U6 applies a low to U8-39. A list of tuning elements used to achieve the 1.5:1 VSWR is stored in the microcomputer memory, and the microcomputer begins the termination of tuning sequence. U8-32 goes low to turn U5C off. If a 1.5:1 VSWR cannot be achieved, the tuner reverts to the tuning configuration previously stored in the

microcomputer memory and begins the termination of tuning sequence.

5.4.6 Termination of Tuning Sequence

U8-33 goes high to allow the radio to revert to the receive mode. The microcomputer memory retains a list of the circuit elements that were switched in when the sequence ended. Circuit elements remain selected until there is a voltage transition at ANT TUNE (VIO), SWITCHED A+ (GRN), or CHANNEL CHANGE (BLU). Tuner operation following these transitions is described in the following paragraphs.

5.4.7 Transition At ANT Tune (VIO)

A voltage transition on the ANT TUNE line indicates a change in radio channel from an A channel to a B channel, or vice versa. The voltage transition is applied via U5F and U9 to U8-11. All tuning elements are switched out and the microcomputer begins initialization and 4:1 VSWR detection.

5.4.8 Transition At SWITCHED A+ (GRN)

If voltage is removed from the SWITCHED A+ line, the list of selected circuit elements stored in the microcomputer memory is lost. When power is reapplied to the SWITCHED A+ line, the microcomputer is reset and the initialization and 4:1 VSWR detection process begins.

5.4.9 Transition At Channel Change

When a channel is changed using the channel selection knob on the radio, a positive going pulse is applied to the CHANNEL CHANGE line (BLU). A low is applied to U8-34 and U8-39 to inhibit tuning until channel selection is complete. One-half second after channel selection is complete, there is a low to high transition at U8-34 and U8-39 and a high to low transition at U8-28. The microcomputer then goes through initialization and 4:1 VSWR detection.

5.4.10 Tune Power Variations

5.4.10.1 If, during a tuning sequence, the tune power level falls below 1 watt or rises above 6 watts for more than two seconds, the tuning sequence is stopped. The tuner reverts to the circuit configuration previously stored in the microcomputer memory. This configuration is used for antenna matching until there is a channel change and the tune power is between 1 and 6 watts. When these two conditions are met the microcomputer goes to initialization and 4:1 VSWR detection.

5.4.10.2 If tune power falls outside the 1 to 6 watt range for less than 2 seconds, the microcomputer resumes the tuning sequence that was underway prior to the level change.

*Automatic Antenna Tuner
Troubleshooting Chart
Motorola No. EEPs-30866-O
10/17/80-NWP*

CHECK TUNE
CIRCUIT IN RADIO

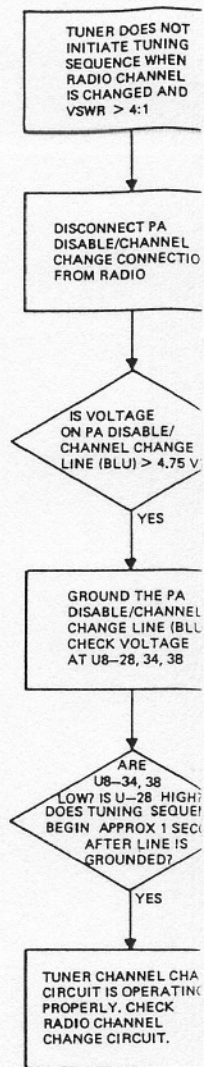
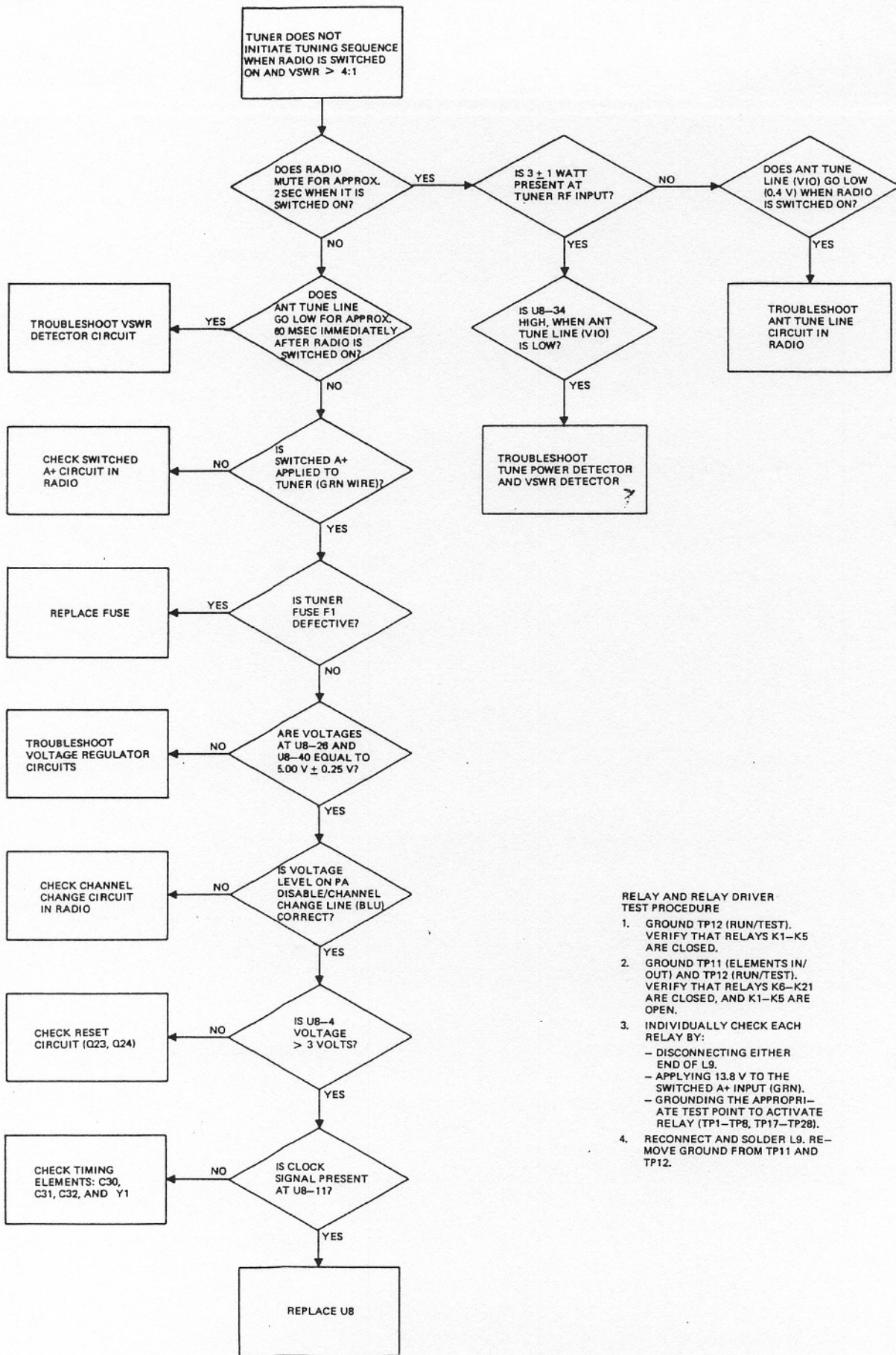

RELAY AND RELAY DRIVER TEST PROCEDURE

- GROUND TP12 (RUN/TEST). VERIFY THAT RELAYS K1-K5 ARE CLOSED.
- GROUND TP11 (ELEMENTS IN/OUT) AND TP12 (RUN/TEST). VERIFY THAT RELAYS K6-K21 ARE CLOSED, AND K1-K5 ARE OPEN.
- INDIVIDUALLY CHECK EACH RELAY BY:
 - DISCONNECTING EITHER END OF L9.
 - APPLYING 13.8 V TO THE SWITCHED A+ INPUT (GRN).
 - GROUNDING THE APPROPRIATE TEST POINT TO ACTIVATE RELAY (TP1-TP8, TP17-TP28).
- RECONNECT AND SOLDER L9. REMOVE GROUND FROM TP11 AND TP12.

VSWR DETECTOR TEST PROCEDURE

- CONNECT RF OUT TO ANTENNA OR DUMMY LOAD.
- APPLY +5 V TO TP13 SLOW TUNING MODE AT 2 Hz RATE.
- TURN ON RADIO TO SWITCHED A+ TO TUNER.
- MONITOR VOLTAGE AND J8-39. VOLTAGE SHOULD GRADUALLY INCREASE. TUNING SEQUENCE CONDITION IS APPROPRIATE WHEN VOLTAGE IS APPROX 1 SECOND DURING TUNING.

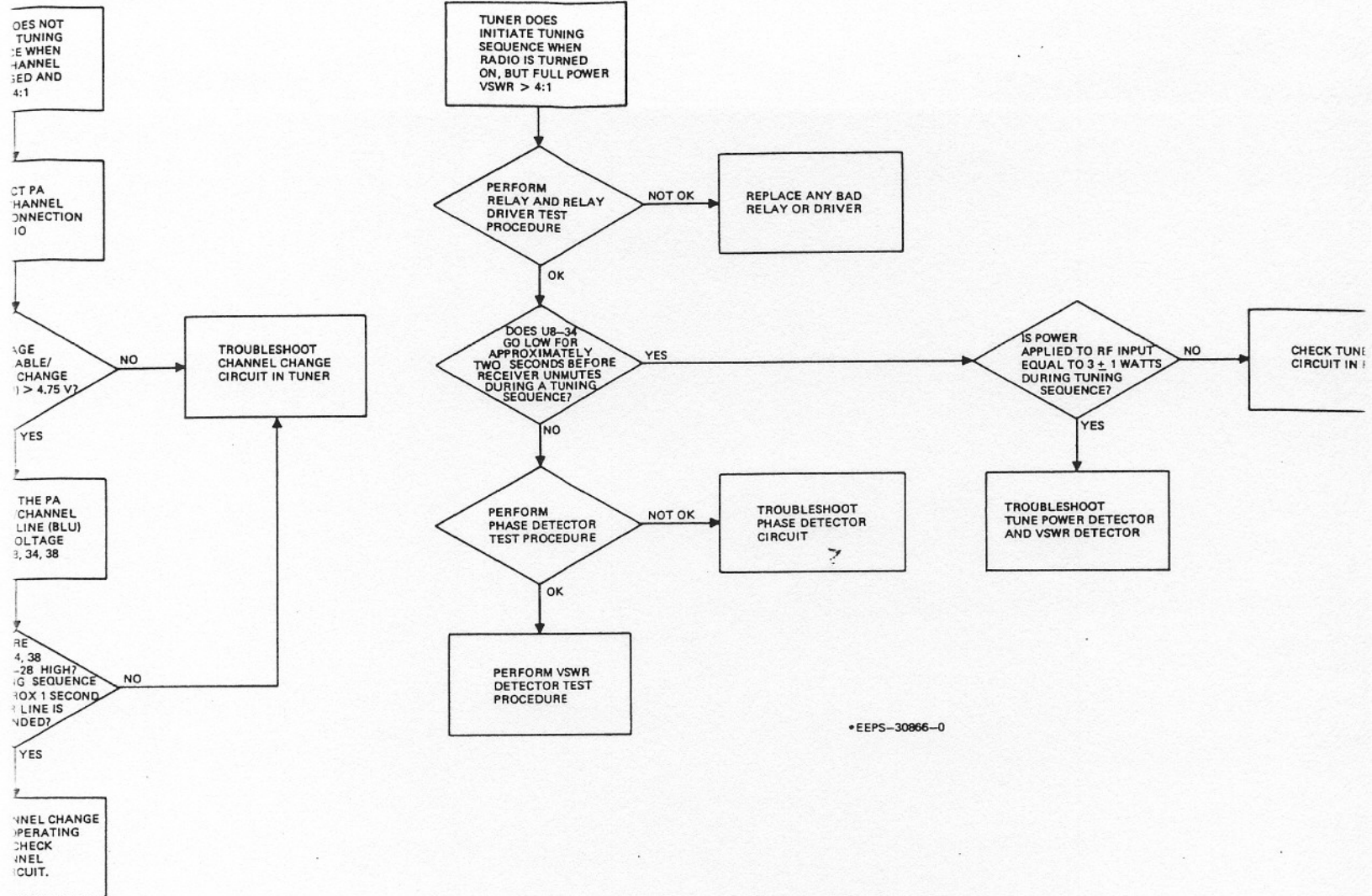

*EEPS-30866-0

RELAY DRIVER TEST PROCEDURE
 1. DISCONNECT RF OUT TERMINAL TO ANTENNA OR DUMMY LOAD.
 2. APPLY 3 WATT RF SIGNAL TO TP13 TO ENABLE TUNING MODE (SWITCHING MODE).
 3. TURN RADIO TO APPLY POWER TO TUNER.
 4. MEASURE VOLTAGE AT U6-11.
 5. VOLTAGE AT U6-11 SHOULD RADIALLY DROP DURING TUNING SEQUENCE AS MATCHED FREQUENCY IS APPROACHED. U8-39 SHOULD GO LOW FOR APPROXIMATELY TWO SECONDS DURING TUNING SEQUENCE.

PHASE DETECTOR TEST PROCEDURE
 1. DISCONNECT ANTENNA FROM RF OUT TERMINAL.
 2. (T1960A AND T1962A MODELS ONLY) CONNECT A 560 PF CAPACITOR FROM RF OUT TERMINAL TO GROUND.
 3. GROUND TP11 AND TP12. UNSOLDER AND REMOVE EITHER END OF R112.
 4. APPLY 3 WATT RF SIGNAL TO RF INPUT TERMINAL.
 5. VARY FREQUENCY OF RF INPUT. MEASURE VOLTAGE AT U8-1. VOLTAGE SHOULD BE LOW WHEN INPUT FREQUENCY IS BELOW 6.5 MHZ, AND HIGH WHEN INPUT FREQUENCY IS ABOVE 7.5 MHZ.
 6. RECONNECT AND SOLDER R112. REMOVE GROUND FROM TP11 AND TP12.

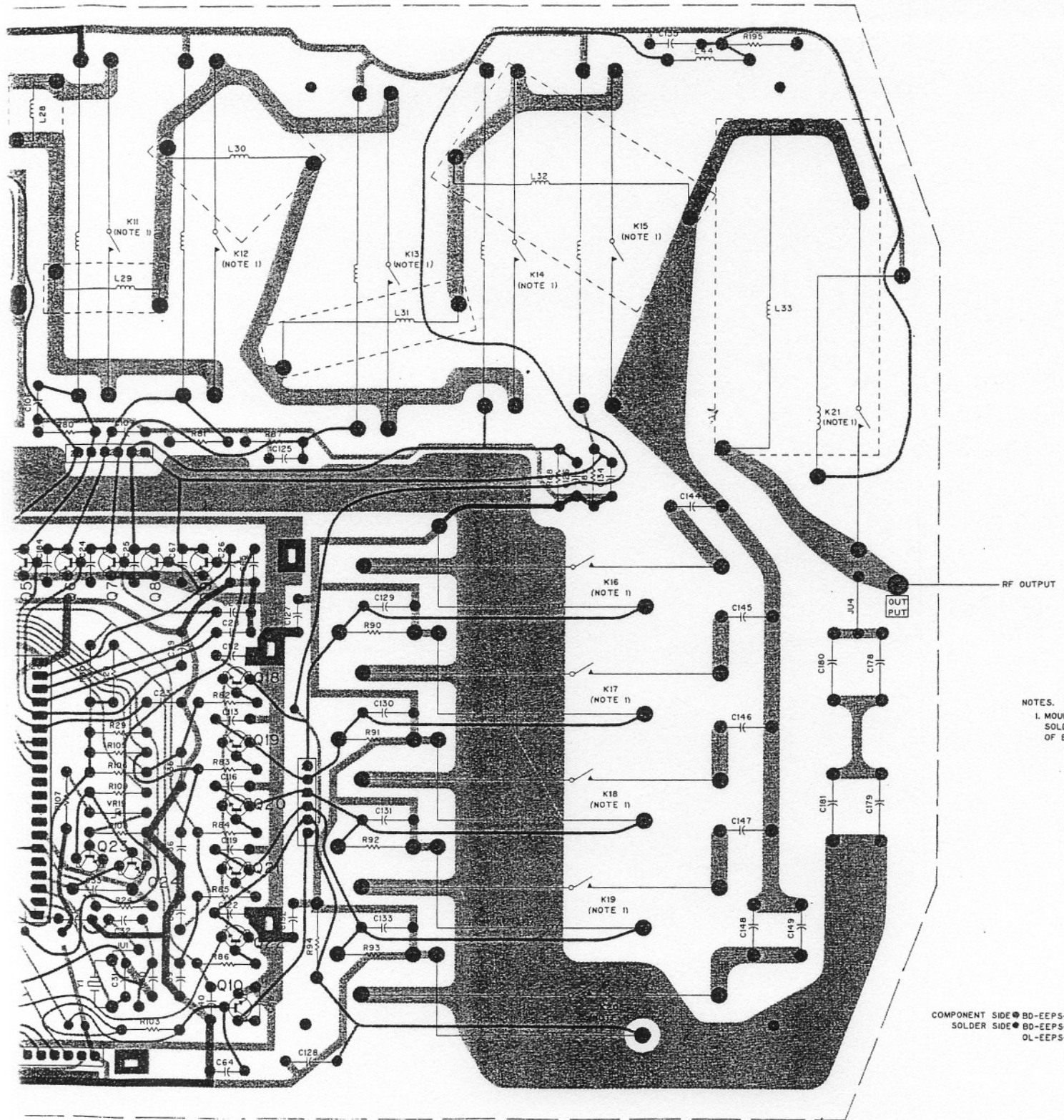

NOTES.
 1. MOUNTED ON
 SOLDER SIDE
 OF BOARD.

COMPONENT SIDE ● BD-EPS-30254-0
 SOLDER SIDE ● BD-EPS-30255-0
 OL-EPS-30256-A

COMPONENT SIDE

BOARD DETAIL

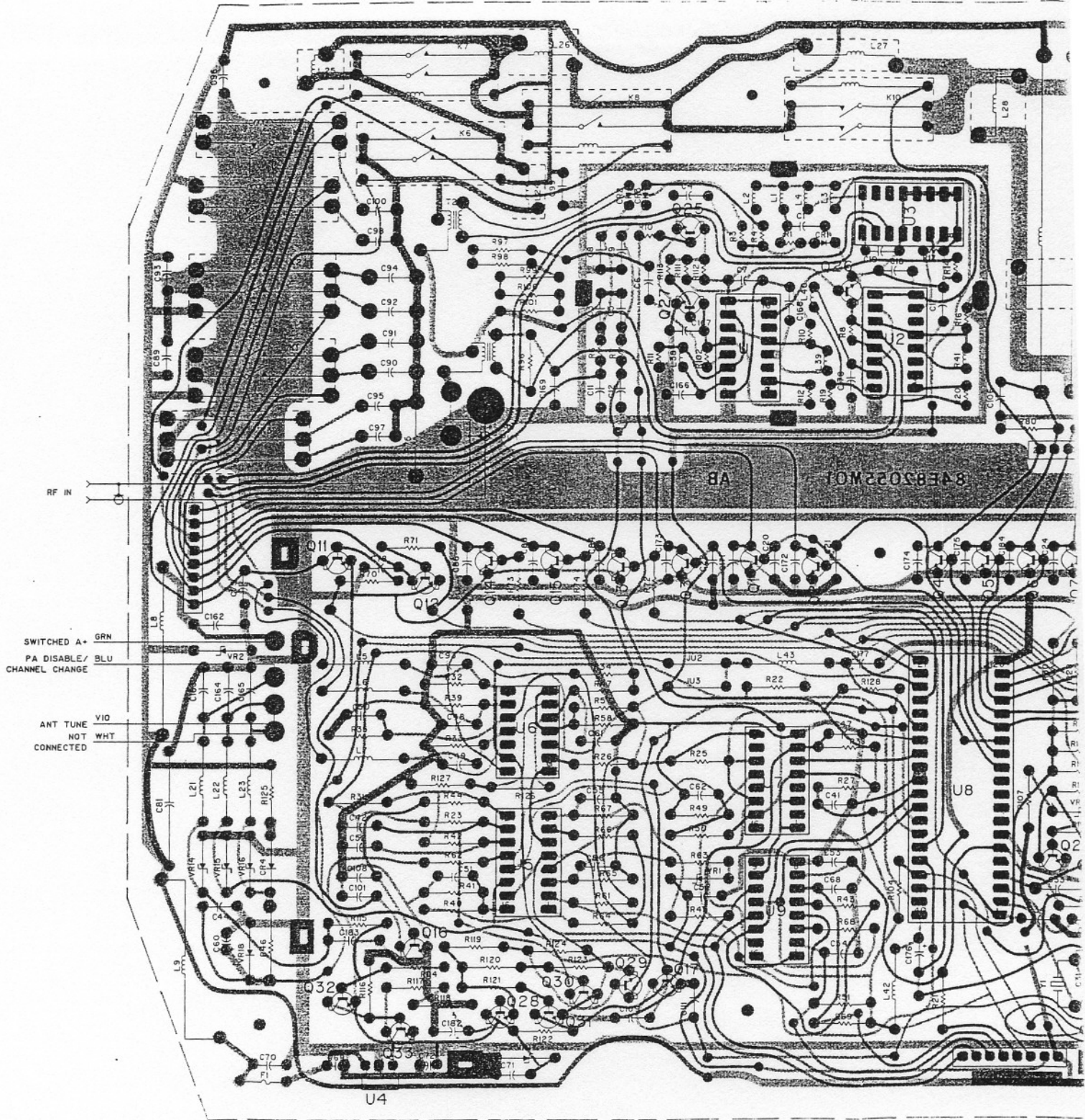

ward Detail and
List and
-31100-A

SHOWN FROM COMPONENT

RF BOARD CIRCUIT BOARD

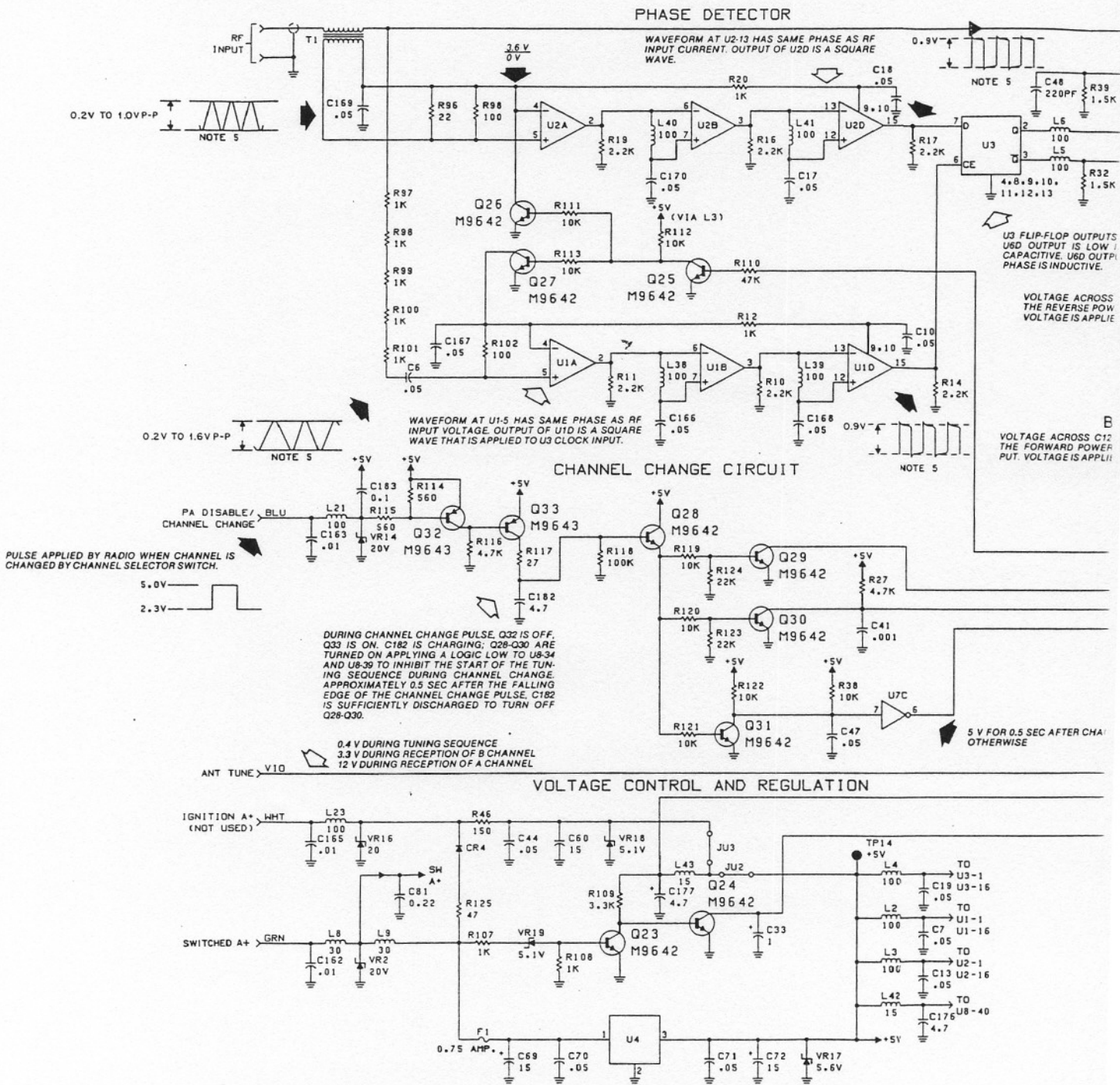

DURING CAP PHASE
U6-9: 3.2 V
U6-8: 4.1 V
DURING IND PHASE
U6-9: 4.1 V
U6-8: 3.2 V

BASE VOLTAGE
1.4 V TO CLOSE RELAY
7 WATTS: U8-1 GOES LOW TO TURN OFF USA,
WHICH IN TURN STOPS THE TUNING SE-
QUENCE. IF RF INPUT RISES ABOVE
0.8 V TO ENABLE Q16-02.
0 V TO OPEN RELAY
3.2 V IF Q16 IS OFF

DURING TUNING SEQUENCE: IF RF INPUT
DROPS BELOW 1 WATT, U6-2 GOES LOW TO
TURN OFF USA, WHICH IN TURN STOPS THE
TUNING SEQUENCE. IF RF INPUT RISES ABOVE
7 WATTS: U8-1 GOES LOW TO TURN OFF USA,
WHICH IN TURN STOPS THE TUNING SE-
QUENCE.

0.8 V RELAY CLOSED
13.8 V RELAY OPEN

VSWR DETECTOR

D

C

E

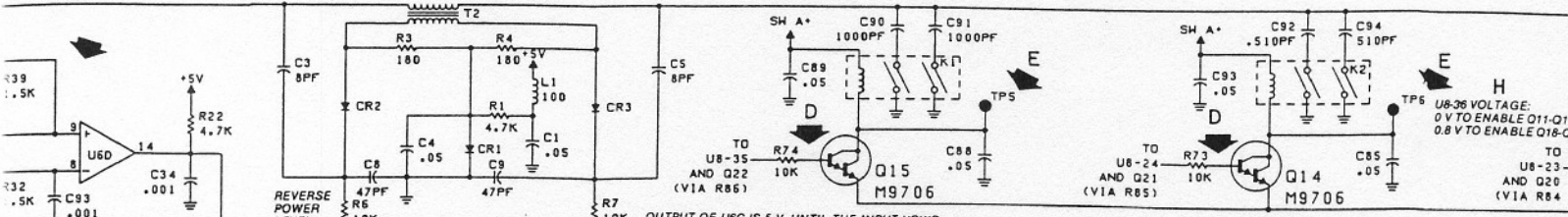

PUTS ARE APPLIED TO U6D.
OW IF RF INPUT PHASE IS
OUTPUT IS HIGH IF RF INPUT
E.

OSS C11 IS PROPORTIONAL TO
POWER AT THE RF TUNER INPUT.
PLIED VIA L7 TO U6C.

B
C12 IS PROPORTIONAL TO
WER AT THE TUNER RF IN-
PLIED VIA R34 TO U5C.

OUTPUT OF U6C IS 5 V, UNTIL THE INPUT VSWR
IS THE SAME AS THE VSWR THAT THE TUNER
MICROPROCESSOR IS TUNING FOR: 4:1, 2:1, OR
1.5:1 AS DETERMINED BY U8-31, U8-32. WHEN
THE APPROPRIATE VSWR IS ACHIEVED, U6-13 IS
0 V.

TUNE POWER DETECTOR

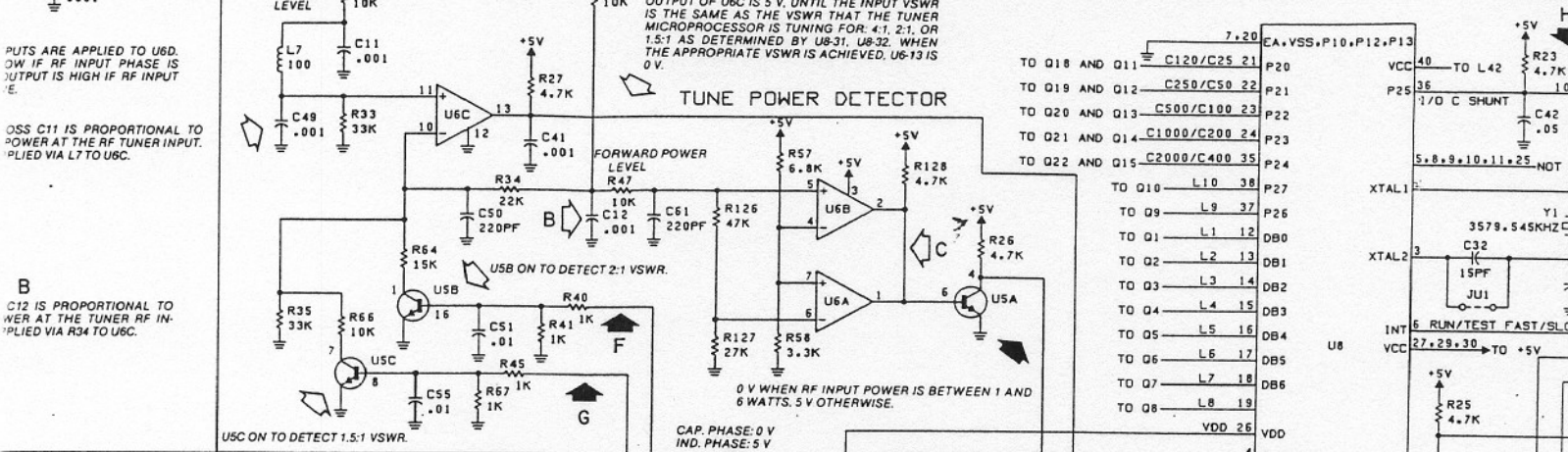

F
4.3 V TO DETECT 2:1 VSWR, 0 V OTHERWISE

G
4.3 V TO DETECT 1.5:1 VSWR, 0 V OTHERWISE.

CHANNEL CHANGE, 0 V

M
IF AN A CHANNEL IS SELECTED, THE RADIO AP-
PLIES A+ TO THE ANT TUNE LINE. USF APPLIES
A LOGIC LOW TO U8-31. IF A B CHANNEL IS
SELECTED ANT TUNE LINE VOLTAGE IS LOW,
USF APPLIES A LOGIC HIGH TO U8-31.

0 V WHEN RF INPUT POWER IS BETWEEN 1 AND
6 WATTS, 5 V OTHERWISE.

CAP PHASE: 0 V
IND. PHASE: 5 V

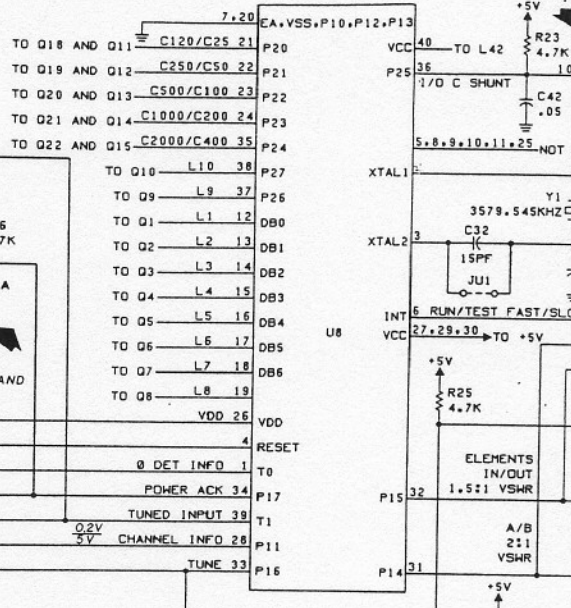

TUNE LINE CIRCUIT

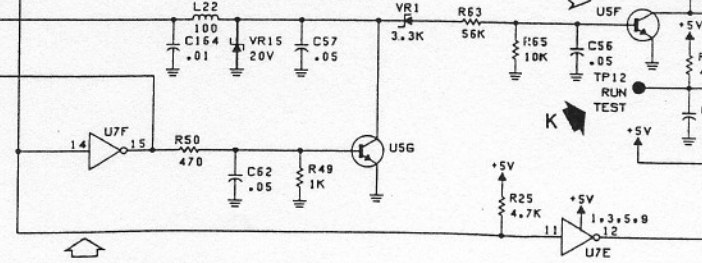

WHEN U8-33 GOES LOW, U7-15 GOES HIGH.
HIGH IS APPLIED TO USG. USG APPLIES A LOW
TO ANT TUNE LINE TO ACTIVATE RADIO TUNE
MODE.

K
GROUNDING TP12 ENERGIZES K1-K5, AND DE-
ENERGIZES K6-K15 AND K21 FOR SERVICING.

0.8 V RELAY CLOSED
13.8 V RELAY OPEN
E

1 (SEE SHEET 2)

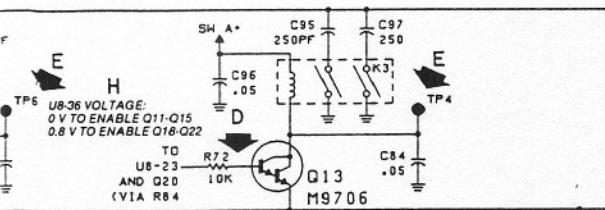

2 (SEE SHEET 2)

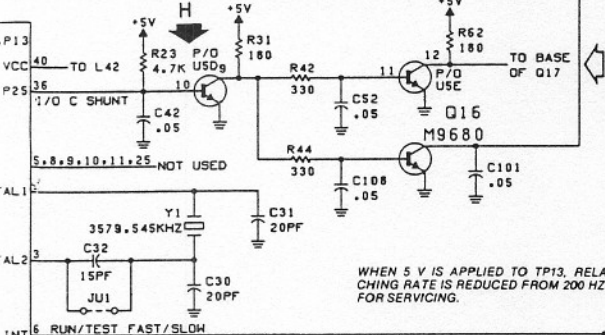

A LOGIC HIGH AT U8-36 TURNS ON U5D, WHICH IN TURN, TURNS OFF USE AND Q16. WHEN USE IS OFF, Q17 IS ON TO ENABLE Q18-Q22. Q18-Q22 DRIVE RELAYS FOR OUTPUT CAPACITANCE. A LOGIC LOW AT U8-36 TURNS OFF U5D, WHICH IN TURN, TURNS ON Q16. Q16 IS ON TO ENABLE Q11-Q15. Q11-Q15 DRIVE RELAYS FOR INPUT CAPACITANCE.

WHEN 5 V IS APPLIED TO TP13, RELAY SWITCHING RATE IS REDUCED FROM 200 HZ TO 2 HZ FOR SERVICING.

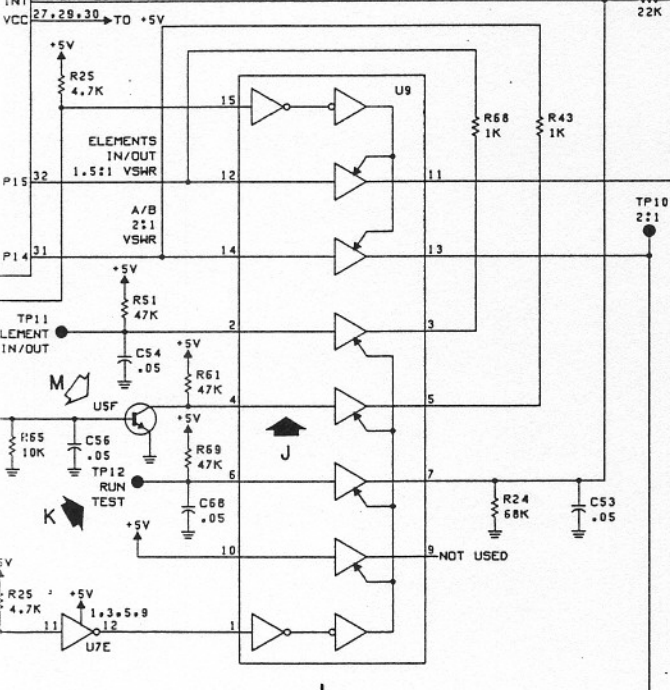

0 V WHEN RADIO SELECTS AN A CHANNEL
5 V WHEN RADIO SELECTS A B CHANNEL

EEPS-30253-A
(SHT 1 OF 2)